

FEATURES

- Operates from a Single +5V Supply**
- On-Board Reference and Digital Buffers**
- Various Linking Options**
- Direct Hook-Up to Printer Port of PC**
- PC Software for Control and Data Analysis**

INTRODUCTION

This Application Note describes the evaluation board for the AD7715-5, 16-Bit signal conditioning ADC. The AD7715 is a complete analog front end for low-frequency applications providing a fully-differential input channel. The device accepts low-level signals directly from a transducer and outputs a serial digital word. It employs a sigma delta technique to realize up to 16 bits of no missing codes performance. Full data on the AD7715-5 is available in the AD7715 data sheet available from Analog Devices and should be consulted in conjunction with this Application Note when using the Evaluation Board.

Included on the evaluation board, along with the AD7715-5, are an AD780, a +2.5 V ultra high precision bandgap reference, a 2.4576MHz crystal and digital buffers to buffer signals to and from the edge connectors.

Interfacing to this board is provided either through a 36-Way Centronics Connector or through a 9-way D-type connector. External sockets are provided for the analog inputs, an external reference input option and an external master clock option.

OPERATING THE AD7715-5 EVALUATION BOARD

Power Supplies

The evaluation board has four power supply input pins: AV_{DD} , AGND, DV_{DD} and DGND. The AD7715-5 is specified with an AV_{DD} of +5V. Therefore, the AV_{DD} voltage supplied to the board must be +5V. This AV_{DD} voltage is also used to power the AD780 reference. The AD7715-5 can be operated from a +5V or +3V DV_{DD} voltage. When using the 9-way D-type connector to interface to the evaluation board it is possible to apply a DV_{DD} voltage of either +3V or +5V to the DV_{DD} input terminal on the board. However, when using the 36-way Centronics connector to interface to the board, the voltage applied to the DV_{DD} input terminal must be +5V. This is because the Centronics connector is intended for connection to the printer port of a PC with signals driven from +5V supplies. To run the board from a single +5V supply, simply connect the AV_{DD} and DV_{DD} inputs together.

Both AGND and DGND inputs are provided on the board. AGND connects to the AD7715-5 AGND pin and also connects to the GND pin of the AD780. DGND connects to the DGND pin of the AD7715 and to the GND of the digital chips on the board. The AGND and DGND planes are connected at the AD7715. Therefore, it is recommended not to connect AGND and DGND elsewhere in the system to avoid ground loop problems. When using a single supply for both AV_{DD} and DV_{DD} , only one ground connection should be made to the board. This connection should be made to the board's AGND input terminal.

Both supplies are decoupled to their respective ground plane with 10 μ F tantalum and 0.1 μ F ceramic disc capacitors.

FUNCTIONAL BLOCK DIAGRAM

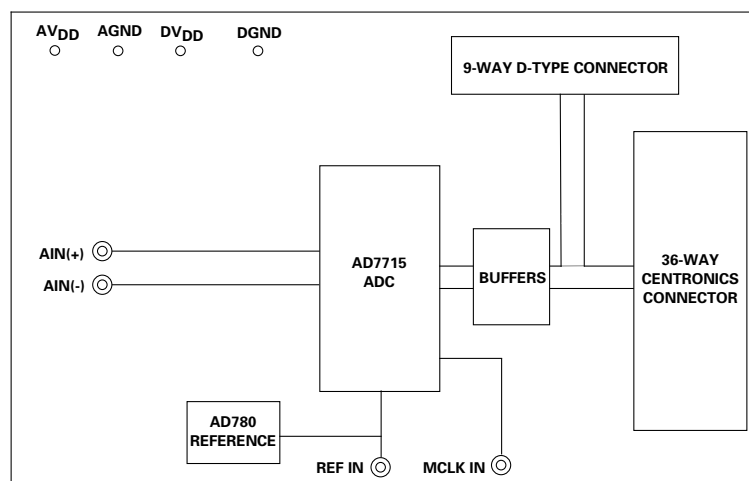

REV. A

Information furnished by Analog Devices is believed to be accurate and reliable. However, no responsibility is assumed by Analog Devices for its use, nor for any infringements of patents or other rights of third parties which may result from its use. No license is granted by implication or otherwise under any patent or patent rights of Analog Devices.

EVAL-AD7715-5EB

Link Options

There are a number of link options on the evaluation board which should be set for the required operating setup before using the board. The functions of these link options are described in detail below.

Link No.	Function
----------	----------

- | | |
|-----|---|
| LK1 | <p>This option selects the master clock option for the AD7715. The master clock source comes from the on-board crystal or from an external clock source via SKT7. This is a double link and both links must be moved together for correct operation.</p> <p>With both links in position A, the external clock option is selected and an externally applied clock to SKT 7 is routed the MCLK IN pin of the AD7715.</p> <p>With both links in position B, the on-board crystal is selected and provides the master clock for the AD7715.</p> |
| LK2 | <p>This link option is used to select the reference source for the AD7715's REF IN(-) input.</p> <p>With this link in position A, the REF IN(-) pin of the AD7715 is connected directly to AGND.</p> <p>With this link in position B, the REF IN(-) pin of the AD7715 is connected to SKT5. An external voltage connected to SKT5 can now be used for REF IN(-).</p> |
| LK3 | <p>This link option is used to select the reference source for the AD7715's REF IN(+) input.</p> <p>With this link in position A, the REF IN (+) pin of the AD7715 is connected directly to the output of the on-board reference, the AD780.</p> <p>With this link in position B, the REF IN(+) pin of the AD7715 is connected to SKT6. An external voltage connected to SKT 6 can now be used for REF IN(+).</p> |
| LK4 | <p>This link option is set depending on the type of reference being used on the evaluation board. Although the board is equipped with an AD780, a REF-192 +2.5V reference can replace it in the same socket. When a REF-192 reference is used on the board, the link should be in either position A or position B. In position A, the REF-192's shutdown pin is connected to DV_{DD}, placing the REF-192 in normal mode of operation. In position B, the REF-192's shutdown pin is connected to DGND, placing the REF-192 in power down mode.</p> <p>When the AD780 reference is used, the link should be in position C as the AD780 does not have a shutdown pin.</p> |
| LK5 | <p>This link is in series with the AIN (+) analog input.</p> <p>With this link in place, the analog input on the SKT3 input is connected directly to the AIN(+) input on the part.</p> <p>This link may be removed so that the input signal at SKT3 can be connected to the component grid for signal conditioning before being applied to the AIN(+) input of the AD7715.</p> |
| LK6 | <p>This link is in series with the AIN (-) analog input.</p> <p>With this link in place, the analog input on the SKT4 input is connected directly to the AIN(-) input on the part.</p> <p>This link may be removed so that the input signal at SKT4 can be connected to the component grid for signal conditioning before being applied to the AIN(-) input of the AD7715.</p> |

Setup Conditions

Table I shows the position in which all the links are set when the evaluation board is sent out.

Table I. Initial Link Positions

Link No.	Position	Function.
LK1	B	Both links in position B to select the on-board crystal oscillator as the master clock for the board.
LK2	A	REF IN(-) connected directly to AGND.
LK3	A	REF IN(+) connected to the output of the on-board AD780 reference.
LK4	C	Selects AD780 as the voltage reference.
LK5	IN	Connects input signal from SKT3 directly to the AIN(+) pin of the AD7715.
LK6	IN	Connects input signal from SKT4 directly to the AIN(-) pin of the AD7715.

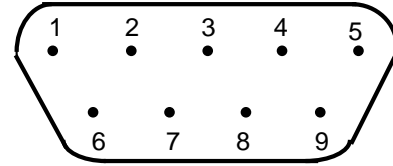

Figure 2. SKT1 Pin Configuration

Table II. SKT1 Pin Designations¹

1	SCLK	Serial Clock. The signal on this pin is buffered before being applied to the SCLK pin of the AD7715.
2	$\overline{\text{DRDY}}$	Logic Output. This is a buffered version of the signal on the AD7715's DRDY pin.
3	$\overline{\text{CS}}$	Chip Select. The signal on this pin is buffered before being applied to the $\overline{\text{CS}}$ pin of the AD7715.
4	$\overline{\text{RESET}}$	Reset Input. The signal on this pin is buffered before being applied to the $\overline{\text{RESET}}$ pin of the AD7715.
5	DIN	Serial Data Input. Data applied to this pin is buffered before being applied to the AD7715's DIN pin.
6	DGND	Ground reference point for digital circuitry. Connects to the DGND plane on the evaluation board.
7	DOUT	Serial Data Output. This is a buffered version of the signal on the AD7715's DOUT pin.
8	DV _{DD}	Digital Supply Voltage. The DV _{DD} voltage for the evaluation board can be supplied via this pin provided no voltage is applied to the main DV _{DD} terminal.
9	NC	No Connect. This pin is not connected on the evaluation board.

NOTE

¹An explanation of the AD7715 functions mentioned here is given in Table III as part of the SKT2 pin designations description.

EVALUATION BOARD INTERFACING

Interfacing to the evaluation board is either via a 9-way D-Type connector, SKT1, or a 36-way Centronics connector, SKT2. The pinout for the SKT1 connector is given in Figure 1 and its corresponding pin designations are given in Table II. The pinout for this SKT2 connector is shown in Figure 2 and its pin designations are given in Table III. The evaluation board should be powered up before a cable is connected to either of the connectors.

SKT2 is used to connect the evaluation board to the printer port (parallel port) of a PC. Connection between the two is direct via a standard parallel printer port cable. SKT1 is used to connect the evaluation board to any other system.

EVAL-AD7715-5EB

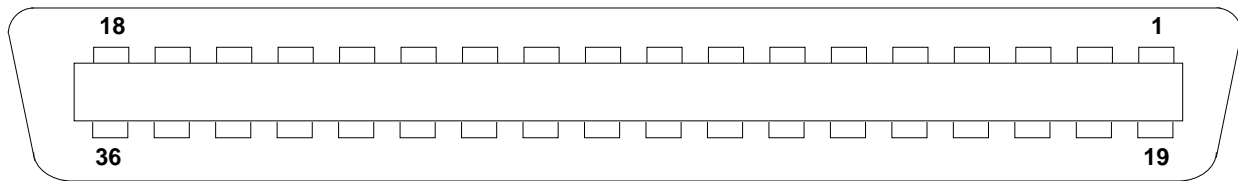

Figure 3. SKT2 Pin Configuration

Table III. SKT2 Pin Designations

1	NC	No Connect. This pin is not connected on the evaluation board.
2	DIN	Serial Data Input. Data applied to this pin is buffered before being applied to the AD7715's DIN pin. The serial data applied to the DIN pin is written to the input shift register on the part. Data from this input shift register is transferred to the communications register or setup register depending on the register selection bits of the Communications Register.
3	$\overline{\text{RESET}}$	Reset Input. The signal on this pin is buffered before being applied to the $\overline{\text{RESET}}$ pin of the AD7715. $\overline{\text{RESET}}$ is an active low input which resets the control logic, interface logic, calibration coefficients, digital filter and analog modulator of the part to power-on status.
4	$\overline{\text{CS}}$	Chip Select. The signal on this pin is buffered before being applied to the $\overline{\text{CS}}$ pin of the AD7715. $\overline{\text{CS}}$ is an active low logic input used to select the AD7715. With this input hard-wired low, the AD7715 operates in its three-wire interface mode with SCLK, DIN and DOUT used to interface to the device. $\overline{\text{CS}}$ can be used to select the device in systems with more than one device on the serial bus or as a frame synchronisation signal in communicating with the AD7715.
5	SCLK	Serial Clock. The signal on this pin is buffered before being applied to the SCLK pin of the AD7715. An external serial clock is applied to this input to access serial data from the AD7715. This serial clock can be a continuous clock with all data transmitted in a continuous train of pulses. Alternatively, it can be a non-continuous clock with the information being transmitted to the AD7715 in smaller batches of data.
6-8	NC	No Connect. These pins are not connected on the evaluation board.
9	DV _{DD}	Digital Supply Voltage. This provides the supply voltage for IC4, the buffer chip which buffers the output signals from the AD7715 before they are applied to SKT2.
10	$\overline{\text{DRDY}}$	Logic output. This is a buffered version of the signal on the AD7715's $\overline{\text{DRDY}}$ pin. A logic low on the $\overline{\text{DRDY}}$ output indicates that a new output word is available from the AD7715 data register. The $\overline{\text{DRDY}}$ pin will return high upon completion of a read operation of a full output word. If no data read has taken place, after an output update, the $\overline{\text{DRDY}}$ line will return high for $500 \cdot t_{\text{CLK IN}}$ cycles prior to the next output update. This gives an indication of when a read operation should not be attempted to avoid reading from the data register as it is being updated. $\overline{\text{DRDY}}$ is also used to indicate when the AD7715 has completed its on-chip calibration sequence.
11-12	NC	No Connect. These pins are not connected on the evaluation board.
13	DOUT	Serial Data Output. This is a buffered version of the signal on the AD7715's DOUT pin. Serial data from the output shift register on the part is clocked out on this pin. This output shift register can contain information from the communications register, setup register or data register depending on the register selection bits of the Communications Register.
14-18	NC	No Connect. These pins are not connected on the evaluation board.
19-30	DGND	Ground reference point for digital circuitry. Connects to the DGND plane on the evaluation board.
31-36	NC	No Connect. These pins are not connected on the evaluation board.

SOCKETS

There are seven sockets on the AD7715-5 evaluation board. The function of these sockets is outlined in Table IV.

Table IV. Socket Functions

Socket	Function
SKT1	9-Way D-Type Connector which can be used for digital interfacing to the evaluation board.
SKT2	36-Way Centronics Connector which can be used for digital interfacing to the evaluation board. This connector should be used when connecting the board to the parallel printer port of the PC to use the evaluation software.
SKT3	Sub-Minature BNC Connector. The analog input signal for the AIN(+) input of the AD7715 is applied to this socket.
SKT4	Sub-Minature BNC Connector. The analog input signal for the AIN(-) input of the AD7715 is applied to this socket.
SKT5	Sub-Minature BNC Connector. The reference voltage for the REF IN(-) input of the AD7715 is applied to this socket when the board is configured for an externally-applied reference voltage.
SKT6	Sub-Minature BNC Connector. The reference voltage for the REF IN(+) input of the AD7715 is applied to this socket when the board is configured for an externally-applied reference voltage.
SKT7	Sub-Minature BNC Connector. The master clock signal for the MCLK IN input of the AD7715 is applied to this socket when the board is configured for an externally-applied master clock.

RUNNING THE AD7715 INTERFACE SOFTWARE

Included in the evaluation board package is a PC-compatible disk which contains software for controlling and evaluating the performance of the AD7715 using the printer port of a PC. There are a total of thirteen files on the distribution disk.

To use the software, the user must have an IBM-compatible PC and Windows 3.1 must be installed. Start Windows and, using either the RUN command or the file manager, start the program called SETUP.EXE on the distribution disk. This automatically installs the application and sets up a window called ANALOG DEVICES. The application ICON is found here. To start the application, double click on the ICON.

When the program starts, the user is asked to select a printer port. The correct selection depends on what type of computer is being used (Desktop, Laptop etc). LPT1 works for most machines. When using a Compaq laptop, select PRN. A different port can be selected at any time from the MAIN MENU.

The evaluation software does not allow another application running under Windows to access the printer port while it is running. Control of the printer port is returned when the application is quit.

EVAL-AD7715-5EB

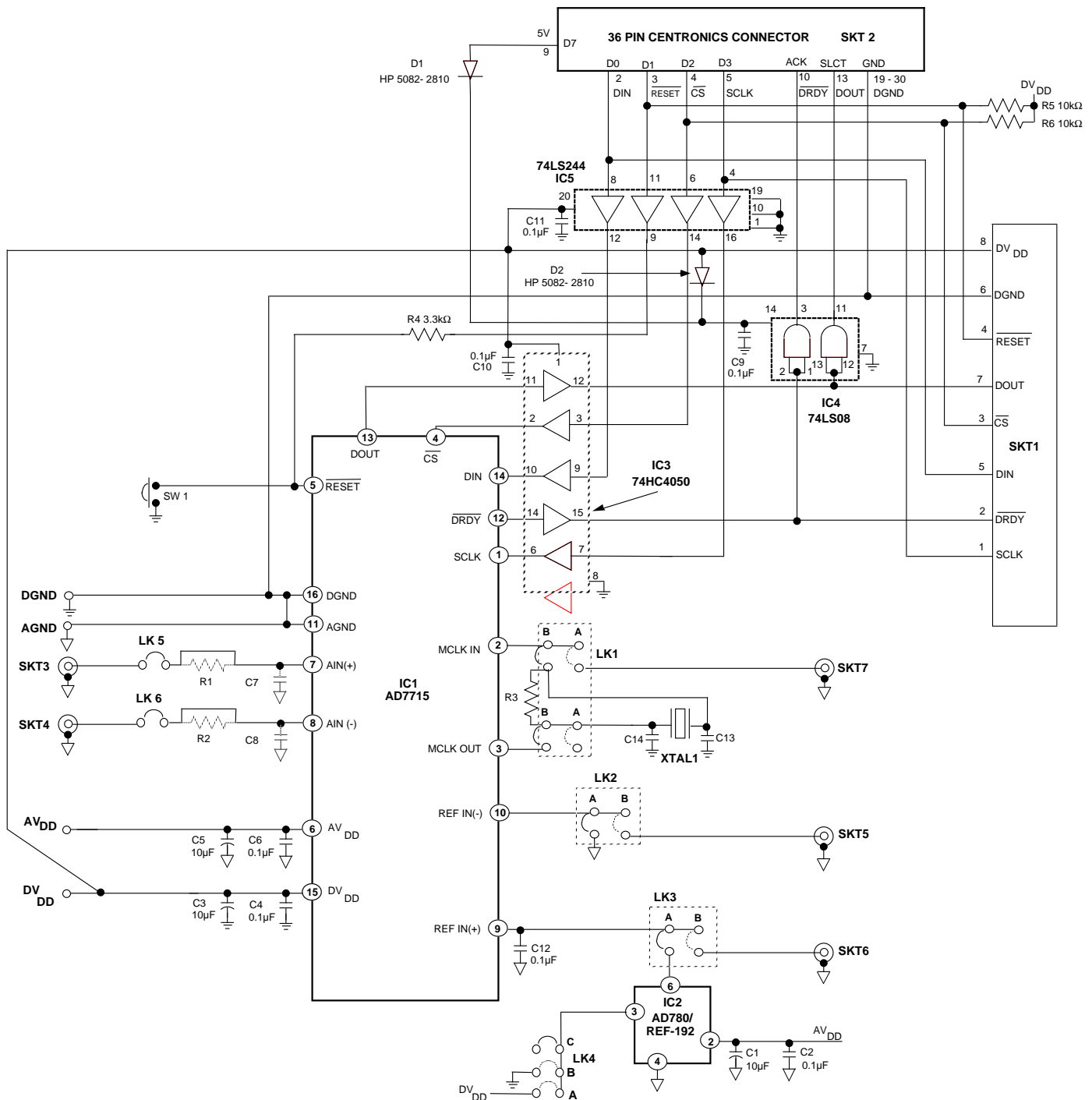

Figure 3. AD7715-5 Evaluation Board Circuit Diagram

COMPONENT LISTING AND MANUFACTURERS

Intergrated Circuits

Component	Location	Vendor
AD7715	IC1	Analog Devices
AD780	IC2	Analog Devices
74HC4050	IC3	Philips
74LS08	IC4	Texas Instruments
74LS244	IC5	Texas Instruments
HP 5082-2810	D1 & D2	Hewlett Packard

Capacitors

Component	Location	Vendor
10 μ F \pm 20% Tantalum (16 V)	C1, C3, C5	AVX- Kyocera Mftrs No TAG106MO16
0.1 μ F Ceramic(X7R \pm 20%)	C2, C4, C6, C9, C10, C11	Philips Mftrs No. CW20C 104M
33pF \pm 2% Ceramic	C13, C14	Philips Mftrs No. 683 34339
Open Circuit	C7, C8,	

Resistors

Component	Location	Vendor
10k Ω \pm 5% 0.25W Carbon Film Resistor	R5, R6	Bourns
3.3k Ω \pm 5% 0.25W Carbon Film Resistor	R4	Bourns
1M Ω \pm 5% 0.25W Carbon Film Resistor	R3	Bourns
Short Circuits	R1, R2	

Link Options

Component	Location	Vendor
Pin Headers	Lk1 (4x2 way) Lk2, Lk3 (2x2 way) Lk4 (3x2 way) Lk5, Lk16 (1x2 way)	Harwin Mftrs No. M20-9993606
Shorting Plugs	Pin Headers (7 required)	Harwin Mftrs No. M7571-05

EVAL-AD7715-5EB

Switch

Component	Location	Vendor
Push Button Switch	SW1	Omron Mftrs No. B3F1000

Sockets

Component	Location	Vendor
Miniature BNC Connectors	SKT3 - SKT 7	M/A - Com Greenpar Mftrs No. C65N07G999X99
9-Way D-Type Connector	SKT1	McMurdo Mftrs No. SDE9PNTD
36 Way Centronics Connector	SKT 2	Fujitsu Mftrs No. FCN785J036G0
16-Pin IC Socket	IC1	Harwin
8 Pin IC Socket	IC2	Mftrs No. D28xx-01
16-Pin IC Socket	IC3	xx = No. of Pins
14- Pin IC Socket	IC4	
20-Pin IC Socket	IC5	
Wire Wrap Pins	DGND, AGND, AVDD, DVDD	Bicc Vero Mftrs No. 663472C

Crystal Oscillator

Component Identification	Location	Vendor
2.4576MHz Oscillator	Xtal 1	IQD Mftrs No. A166C